



FIRE HYDRANT GMC-DBH GLOBE MECHANICAL CONTROL LLC.

PRODUCT FEATURE



1. WEATHER PROOF

THE INTEGRATED WEATHER PROOF COVER DESIGN PROTECTS THE OPERATION NUTS FROM DAMAGE OF BAD WEATHER (ICE, RAIN, ETC.) & DIRT (DUST, SOIL, ETC.).

2. SELF-LUBRICATION

THE INTEGRATED VALVE COVER DESIGN FORMS AN ENCLOSED OIL CHAMBER WHICH KEEPS THE OPERATION NUTS AND STEM THREADS PERMANENTLY LUBRICATED TO ENSURE LOW OPERATING TORQUE AND PROLONGED SERVICE LIFE.

3. TRAFFIC FLANGE DESIGN

THE FLANGE AT THE CONNECTION BETWEEN UPPER CYLINDER (THE MAIN BODY) AND THE LOWER TUBE IS SPECIALLY DESIGNED WITH A BREAK-OFF RING AND FEATURES HIGH ADJUSTABILITY AND INTERCHANGEABILITY. WHEN SUBJECT TO IMPACT OUTSIDE, THE FRAGILE FLANGE, AND THE EASILY BREAKABLE COUPLING BETWEEN THE UPPER AND LOWER VALVE STEMS WILL BREAK TO EFFECTIVELY PROTECT THE MAIN BODY OF THE FIRE HYDRANT FROM DAMAGE.

4. EASY-TO-BREAK COUPLING

THE COUPLING CAN BE BROKEN WITH A SMALL SHOCK, WHICH MAKE REPAIRS MORE EFFICIENT.

5. RELIABLE TAPERED SEAL

TAPERED SEALING STRUCTURE MAKES THE SEAL SOLID AND RELIABLE.

6. USE, INSTALLATION, AND MAINTENANCE IS EASY AND RELIABLE.



MATERIAL SPECIFICATION

Part No.	Part	Standard Specification	Options
1	Elbow	ASTM A536, 65-45-12	
2	Bottom Plate	ASTM A536, 65-45-12	
3	Lower Barrel	ASTM A536, 65-45-12	
4	Lower Stem	ASTM 1045	AISI 420
5	Upper Stem	ASTM 1045	AISI 420
6	Upper Barrel	ASTM A536, 65-45-12	
7	Hydrant Cap	ASTM A536, 65-45-12	
8	4.5" Nozzle	C83600	AISI 420
9	4.5" Nozzle Cap	ASTM A536, 65-45-12	
10	2.5" Nozzle	C83600	AISI 420
11	2.5" Nozzle Cap	ASTM A536, 65-45-12	
12	Half Flange	ASTM A126 Class B	ASTM A536, 65-45-12
13	Drain Valve	Copper	
14	Seat Ring	NBR	EPDM
15	Stem Breaking Coupling	ASTM A126 Class B	ASTM A536, 65-45-12
16	Drain Valve Seat	NBR	EPDM

Note: For special material request other than standard specification, please indicate clearly on the inquiry or order list.

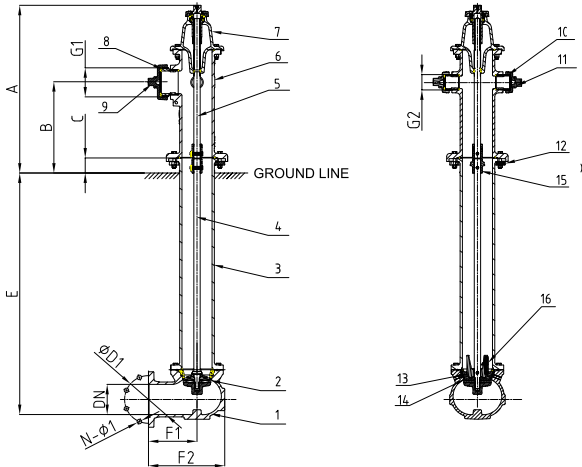

DN		Base Valve Size		Dimensions(mm)									
Inch	mm	Inch	mm	A	B	C	E	D1	N-φ1	F1	F2	G1	G2
6"	150	5-1/4"	128	846	460	76	1219	Φ241.3	8-Φ22.2	245	385	1-4.5"	2-2.5"

NAMEPLATE

